

# Thermal Analysis of Heat Transfer Through Fins of a Four Stroke Internal Combustion Engine Using Different Research Octane Number (RON) Gasoline Fuels

Fairosidi Idrus<sup>1,\*</sup>, Yusli Yaakob<sup>1</sup> and Muhammad Wafiq Farhat Mohd Norhisham<sup>1</sup>

<sup>1</sup>School of Mechanical Engineering, College of Engineering, Universiti Teknologi MARA, 13500 UiTM Permatang Pauh, Penang, Malaysia

Corresponding Author's Email: <sup>1</sup> [shidee@uitm.edu.my](mailto:shidee@uitm.edu.my)

Article History: Received 13092024; Revised 10102024; Accepted 04112024;

**ABSTRACT** –The heat transfer processes in an internal combustion engine can be modelled with a variety of methods. These methods range from simple thermal networks to multi-dimensional differential equation modelling. For thermal analysis of the engine cylinder fins, it is more beneficial to know the heat dissipation inside the cylinder. Fins are placed on the surface of the cylinder to enhance the amount of heat transfer by convection. The goal of this research is to analyse and compare the heat dissipation through rectangular fins of a four-stroke internal combustion (IC) engine of using different Research Octane Number (RON) gasoline fuels; RON 95, RON 97, and RON 100. An experiment has been conducted on a single-cylinder four-stroke IC engine in a Thermodynamics laboratory and the temperature on the cylinder fins surface are measured by using an infrared thermometer. The fins are designed by SOLIDWORKS and the thermal analysis is carried out by ANSYS. The thermal analysis data indicates that there is a corresponding rise in temperature for RON 100, indicate superior resistance to knocking in comparing to RON 95 and RON 97. RON 100 consistently exhibited the highest temperatures on the fins, implying potential variations in heat dissipation and combustion efficiency.

**KEYWORDS:** Heat transfer, Fins, Convection, Heat Dissipation, Internal Combustion Engine

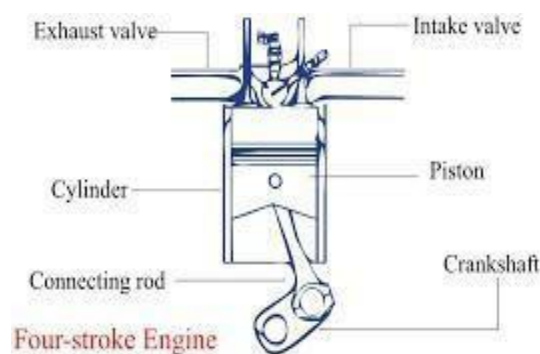
## 1.0 INTRODUCTION

### 1.1 Background of Study

Thermal analysis techniques are widely used in materials science, chemistry, and engineering to understand the behaviour of materials in a variety of applications, such as in the development of new materials, the optimization of manufacturing processes, and the study of the thermal stability of pharmaceuticals and other chemical compounds. [1-2]. The thermal analysis contains a variety of methods used to investigate the reactions of materials as temperatures are different. These methods are used to determine how a material's characteristics be different in response to temperature changes, such as melting point, phase transitions, thermal expansion, and heat capacity. [2]. Heat transfer is a broad area that is applied in the investigation of internal combustion engine heat transfer impact parameters involving performance, emissions, and efficiency. It is said that increasing the heat transfer to the combustion wall for a given quantity of fuel decreases the average combustion pressure and temperature, which indirectly reduces the work done by the piston every cycle and so affects the specific power [3-4].

An engine, often known as a motor, is a mechanism that converts one or more kinds of energy into mechanical energy. Potential energy, thermal energy, chemical energy, electric potential, and nuclear energy (from nuclear fission or nuclear fusion) are all available energy sources. Since many of these processes create heat as an intermediate energy source, heat engines are crucial. Atmospheric convection cells, for example, transform ambient heat into motion. Mechanical energy is very important in transportation, but it is also used in a variety of

industrial activities such as cutting, grinding, crushing, and mixing. [5]. Engine performance is frequently defined by engine operating behavior in the speed-load domain, such as emissions, fuel consumption, noise, mechanical and thermal loads. The constant value contour plots of a certain performance parameter in the speed-torque domain are referred to as engine performance maps. A system design engineer must have a solid grasp of engine performance maps. Optimal system performance for an engine equipped with fixed-geometry hardware and without flexible controls is a substantial compromise between high-speed and low-speed operations, or between high-load and low-load operations. [6]. A four-stroke engine as shown in Figure 1 is an internal combustion (IC) engine in which the crankshaft rotates while the piston performs four different strokes. A piston's whole journey in either direction along the cylinder is referred to as a stroke. The most popular internal combustion engine type for motorized land transportation is the four-stroke engine, which is used in cars, trucks, diesel trains, light aircraft, and motorbikes. [7]



**Figure 1:** Components of four-stroke engine [8]

An internal combustion engine's capacity to sustain compression without igniting a fuel is measured by its octane rating, often known as octane number. The fuel's ability to resist compression before igniting increases with increasing octane numbers. The octane rating of a fuel just reflects how well it can withstand compression and has no direct relationship to the fuel's power output or energy content per unit mass or volume. The engine's design determines whether a higher-octane gasoline enhances or degrades an engine's performance. In general, higher-octane fuels are utilized in gasoline engines with greater compression ratios, which may result in these engines producing more power. Instead of coming straight from the gasoline, this increased power is caused by the engine's greater fuel compression. [9]. The engine cylinder is one of the main parts of a car that experiences significant temperature changes and thermal strains. Fins are added to the cylinder's surface to speed up the rate of heat transfer to cool the cylinder [10]. The engine cylinder is one of the most significant automobile components that is subjected to high-temperature variations and thermal strains [11]. The cylinder is the heart of an internal combustion engine. When combustion occurs inside the cylinder, a great amount of heat is produced, and because of that heat, cylinder wall deformation may occur. Because of insufficient heat transport through the engine cylinder block, the engine cylinder overheats, causing banging and, in severe cases, structural collapse [12]. One of the causes of early exhaust valve deterioration is thermal stress caused by non-uniform temperature changes. The thermal analysis aids in precisely measuring heat flow so that temperature distribution may be reduced/optimized to minimize breakdowns due to high loads [13]. A proper valve subdivision is utilized to properly measure the influence of each portion of the cylinder head. As a result, the instantaneous heat transfer coefficient and adiabatic wall temperature for each subdivision

are calculated throughout an engine's four-stroke cycle [14]. It showed that fins are extended surfaces that serve to disperse heat generated in the engine, but their length is restricted, limiting the rate of heat dissipation [15]. Engine fins are used to increase the rate of heat transmission. To boost the heat transmission rate, fins are utilized on the surface of the engine cylinder. By increasing the surface area of engine cylinder fins, the rate of heat dissipation may be increased [16]. The use of fins on the cylinder's surface to enhance heat transfer rates and dissipate internal heat effectively. Thermal analysis of the engine cylinder fins provided valuable insights into heat dissipation, with fins strategically placed around the cylinder's circumference [17].

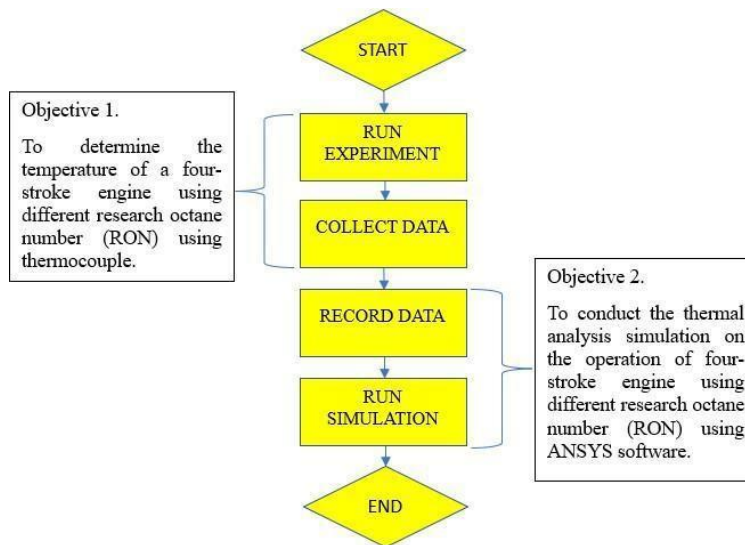
The real octane number is the simple average of two separate octane rating techniques, research octane rating (RON) and motor octane rating (MOR), which differ mainly in the particulars of the operating circumstances. The fuel is more stable the higher the octane number [18]. RON 95 is roughly equivalent to 91-octane on the anti-knock index currently in use in the US. Every automobile has a minimum compression ratio, thus the simplest way to determine which gasoline type to use is to look up the vehicle's minimum octane rating in the service manual or on the fuel lid cover [19]. High-compression engines, which provide more power, often utilize fuels with a higher octane rating, such as RON 97. Increasing RON, on the other hand, appears to provide more benefit to engine brake power and speed for the same octane number change [20]. High compression ratios, on the other hand, frequently result in explosively little quantities of combustion. The advantages of employing the RON 100, particularly for premium engines, are that the weight of the load will permit the use of high compression engines that generate a lot of power (output). The operations of a four-stroke IC engine can be used as efficiently as possible using different research octane number (RON) gasoline fuels; RON 95, RON 97 and RON 100. RON also known as octane rating or level, serves as an indicator of fuel stability. Within the RON classification, numbers indicate the level of pressure generated during fuel combustion within a vehicle's engine. Heat transfer in the cylinder engine is enhanced through extended surfaces and the heat transfer coefficient is affected by changing cross section of the fins. Fins are placed on the surface of the cylinder to enhance the amount of heat transfer by convection.

For thermal analysis of the engine cylinder fins, it is more beneficial to know the heat dissipation inside the cylinder. However, the temperature changes and heat dissipation of the rectangular fins inside the cylinder engine using different RON gasoline fuels are not fully discovered. Therefore, this study is aimed to evaluate the heat dissipation through rectangular fins of a four-stroke internal combustion (IC) engine using different RON gasoline fuels; RON 95, RON 97 and RON 100. The main purpose of the project to measure the temperature of the rectangular fins of a four-stroke IC engine experimentally and to simulate the heat dissipation on the cylinder fins surface using ANSYS simulation.

## **2.0 METHODOLOGY**

### ***2.1 Introduction***

The methodology for this research consists of a few sections. The first section is to run an experiment on a four-stroke engine using different RON gasoline fuels in a Thermodynamics lab at UiTMPP. The second part is to measure the fins surface temperature using an infrared thermometer and record the readings using GRAPHPAD PRISM 9 software. The next section is to simulate the heat dissipation on the fins surface of the four-stroke engine using different RON using ANSYS software. The flow chart of the overall project is illustrated in Figure 2.



**Figure 2:** Research flow chart

## 2.2 Experimental Procedures

This experiment is carried out on a single cylinder four-stroke IC engine in a Thermodynamics Lab at UiTMPP as depicted in Figure 3. Firstly, the initial temperature of the fins engine is measured by using an infrared thermometer as shown in Figure 4. The experiment begins by using RON 95 fuel. Firstly, the power supply is switched on before the tap of fuel tank is turning on. It is important to ensure that the fuel has reached the carburetor from fuel tank. Then the throttle or rack control need to be opened in a small amount. The base must be hold and the starting handle has to be pulled rapidly outwards. The steps must be repeated until the engine runs. The choke has to be returned to the open position as soon as the engine runs smoothly without choke. Then, the throttle or rack control needs to be adjusted to its maximum position. When the engine has settled down to a steady operation, the temperature of the fins engine is measured in every 5 minutes within 15 minutes of operation and at speed of 0, 2600, 2700, and 2800 rpm.



**Figure 3:** Single cylinder four-stroke IC engine

Then, the throttle or rack is kept open and the needle valve is slowly adjusted to increase the flow of water through the dynamometer until the engine speed drops to the next higher selected value. Because the time response of dynamometer is slow, the needle valve must be operated slowly. This process is repeated with three operational speeds. Then, the water flow to the dynamometer has to be reduced. The throttle or rack control must be closed until the regime is running at a fast-idling speed. The throttle or rack control is completely closed. The experiments are then repeated by using RON 97 and RON 100 fuels as shown in Figure 5.



**Figure 4:** Infrared thermometer



**Figure 5:** Three different types of RON fuels

### **2.3 SolidWorks**

SolidWorks allows users to create detailed and realistic 3D models of parts and assemblies. The software provides a variety of tools for sketching, extruding, revolving, sweeping, and lofting, allowing designers to bring their ideas to life in a three-dimensional space. Modelling in SolidWorks enables to create designs that are driven by parameters or dimensions. In this study, SolidWorks has been adapted to model the fins engine for the simulation. The design of the fins is depicted in Figure 6.

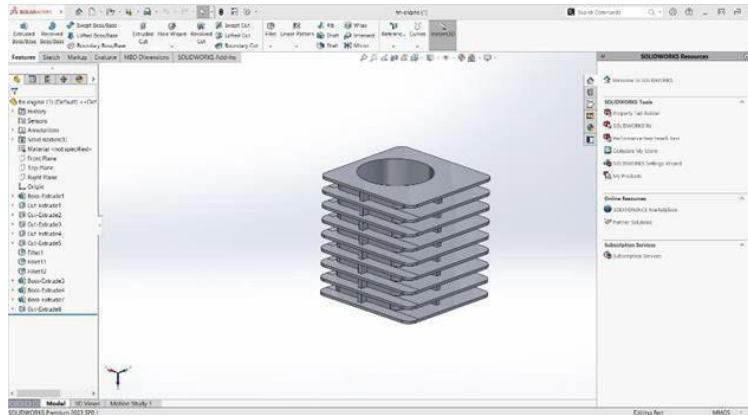


Figure 6: Engine fins design

## 2.4 ANSYS Meshing

ANSYS 2023 enables engineering teams to handle the complex challenges required to develop the next generation of world-changing products. Advances in product design drive the ability to replicate the behaviour of complex systems so you can find novel solutions. For the research, ANSYS 2023 has been applied for the simulation of the engine fins as shown in Figure 7.

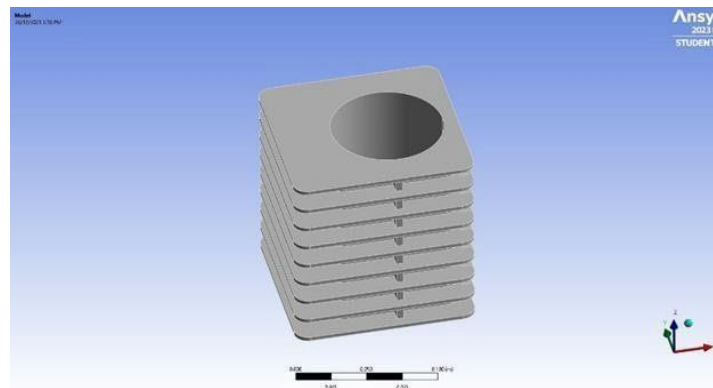


Figure 7: Simulation in ANSYS

In ANSYS, meshing is a crucial step in the finite element analysis (FEA) process. The mesh generation, or meshing, function involves dividing a geometric model into discrete elements to approximate the behaviour of the physical system under analysis. The meshing used in the simulation is presented in Figure 8. The parameter used to setup this simulation is to simulate temperature, isoline and total heat flux.

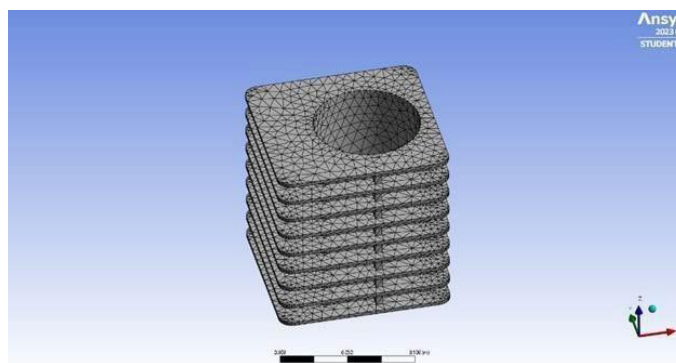
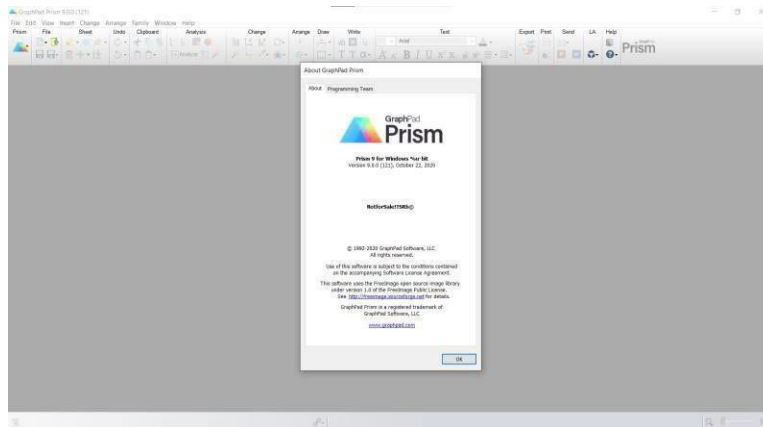


Figure 8: Meshing in ANSYS

## 2.5 Graphpad Prism 9

Prism 9 as shown in Figure 9 makes it easy to create the graphs using taken data. This software can choose the type of graph and customize any part-how the data is arranged, style of your data points, labels, fonts, colours, and much more. The customization options are endless.



**Figure 9:** GraphPad Prism 9

## 3.0 RESULT AND DISCUSSION

### 3.1 Experimental Results

The findings of the experimental work are presented in tables, simulations and graphical. ANSYS is utilized for the steady-state thermal simulation of the fin engines. GraphPad Prism software is then employed to visualize and analyse the data flow by creating graphical representations.

### 3.2 Experimental Analysis of Four Stroke IC Engine

**Table 1:** Results of the experimental based on RON 95

Time (minute)	Temperature (°C)	Speed (rpm)
0	22.7	0
5	99.8	2600
10	112.6	2700
15	121.7	2800

**Table 2:** Results of the experimental based on RON 97

Time (minute)	Temperature (°C)	Speed (rpm)
0	22.7	0
5	106.7	2600
10	123.4	2700
15	135.1	2800

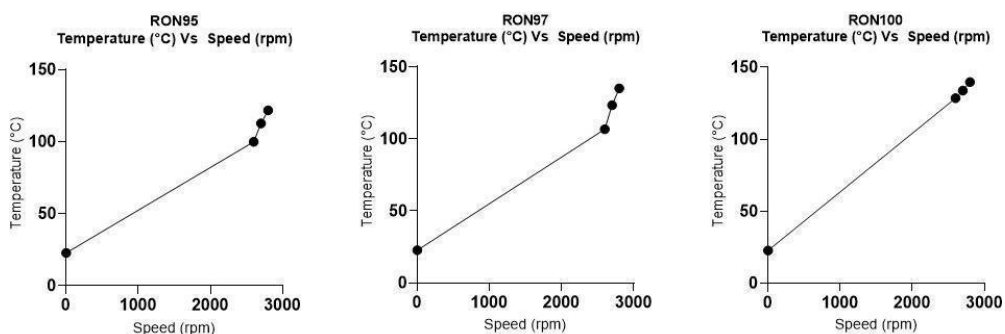
**Table 3:** Results of the experimental based on RON 100

Time (minute)	Temperature (°C)	Speed (rpm)
0	22.7	0
5	128.4	2600
10	133.7	2700
15	139.6	2800

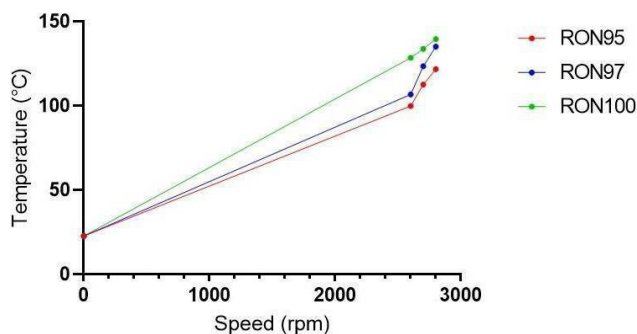
The data shown in Tables 1-3 represent the temperatures and corresponding engine speeds at different time intervals. The observations are carried out at four time points: 0 minutes, 5 minutes, 10 minutes, and 15 minutes. The corresponding engine speeds at these time intervals are 0 rpm, 2600 rpm, 2700 rpm, and 2800 rpm. The engine speed shows an incremental trend over time. The temperature readings for the three types of RON appear to increase over the observed time span. RON 100 exhibits the highest temperatures among the fuels, suggesting potential differences in combustion characteristics or energy content.

The data has been effectively translated into graphical representations using GraphPad Prism software to discern patterns of increase. Through the utilization of this software, the intricacies of the data are visually presented, allowing for a detailed examination of trends and patterns. The graphs serve as a dynamic visualization tool, offering insights into the variations in temperature over time for the three fuel types RON 95, RON 97 and RON 100. The choice of GraphPad Prism software enhances the interpretability of the data, enabling a comprehensive understanding of the temperature dynamics inherent in the experiment.

### 3.1.2 Correlation Between Temperature and Speed

**Figure 10:** Temperature (°C) vs Speed (rpm) of each RON

#### Temperature (°C) Vs Speed (rpm)

**Figure 11:** Temperature (°C) vs Speed (rpm) of all RON



The graphical shown in Figure 10 represents the relationship between temperature and speed in an experiment featuring three different fuel types: RON 95, RON 97, and RON 100. Across the board, the graphs exhibit an upward trend, indicating an increase in temperature with respect to engine speed for all three fuels. Notably, among the fuels, RON 100 exhibits the highest trajectory on the graphs, surpassing both RON 95 and RON 97 in terms of temperature at corresponding speed levels. The RON (Research Octane Number) values indicate the resistance of a fuel to knocking or detonation in an internal combustion engine. Generally, higher RON such as RON 100 values suggest better anti-knock properties compared to RON 95 and RON 97 as illustrated in Figure 11.

### 3.2 ANSYS Simulation

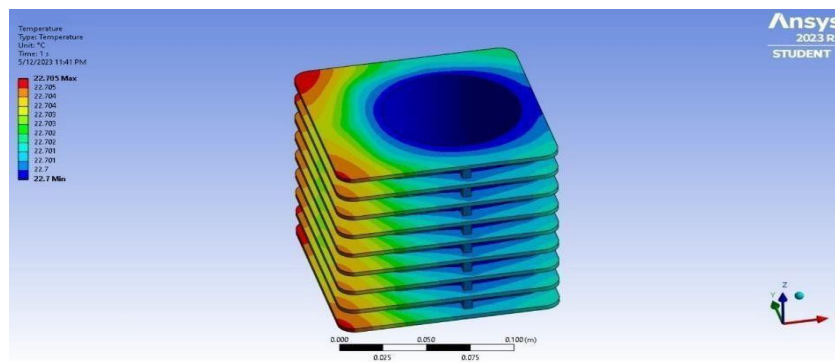


Figure 12: Engine's fin early temperature at 22.7°C

In the initial stages of the experiment as shown in Figure 12, the temperature data for the fin engine revealed a relatively low level, primarily attributable to the prevailing environmental conditions. The early temperature readings reflected the ambient temperature surrounding the fin engine, which, at the onset of the experiment, tends to mirror the environmental conditions in the Thermodynamics Lab. The initial low temperature can be attributed to factors such as the room temperature, the absence of prolonged operational activity, and the time elapsed since the initiation of the experiment. These early readings provide a baseline, capturing the inherent thermal state of the fin engine in its dormant phase before any significant heating or dynamic thermal processes come into play. The acknowledgment of this initial low temperature serves as a crucial reference point for understanding subsequent temperature variations as the fin engine undergoes operational changes and responds to the applied experimental and simulation conditions.

RON 95

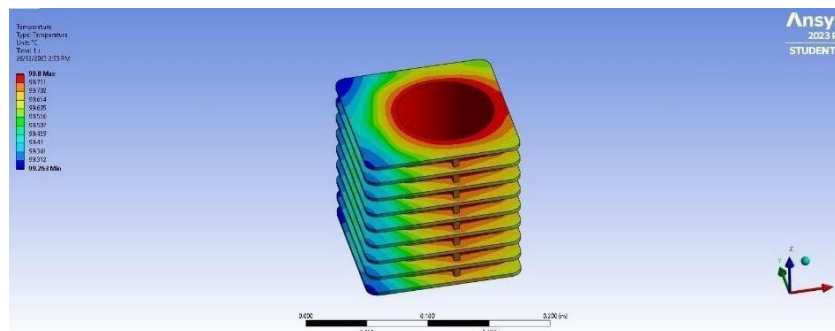
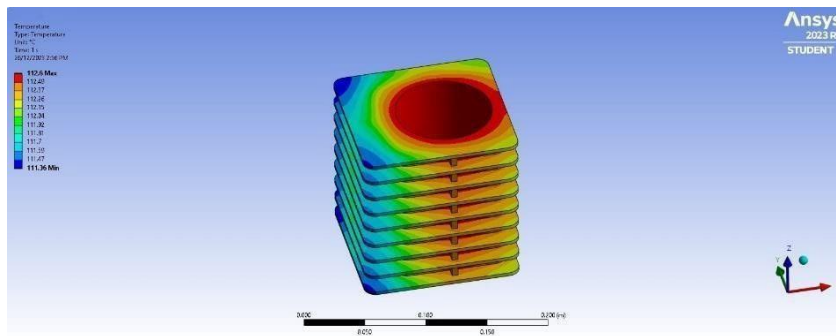
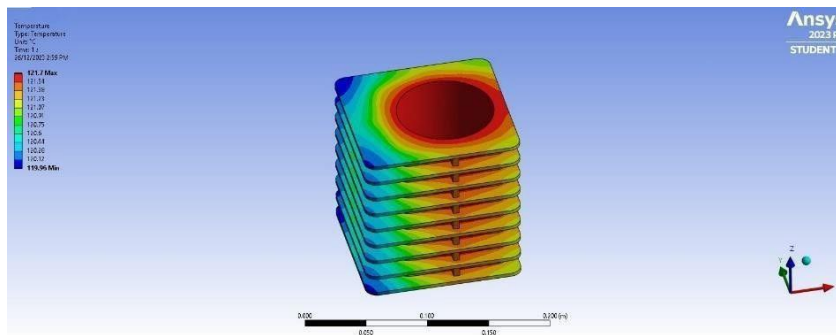


Figure 13: Simulation at 99.8°C

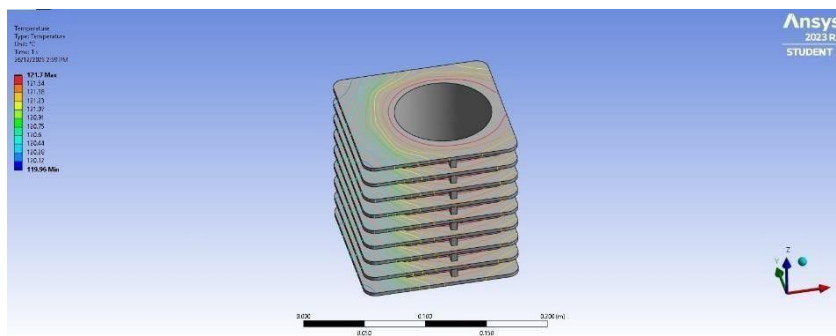


**Figure 14:** Simulation at 112.6°C



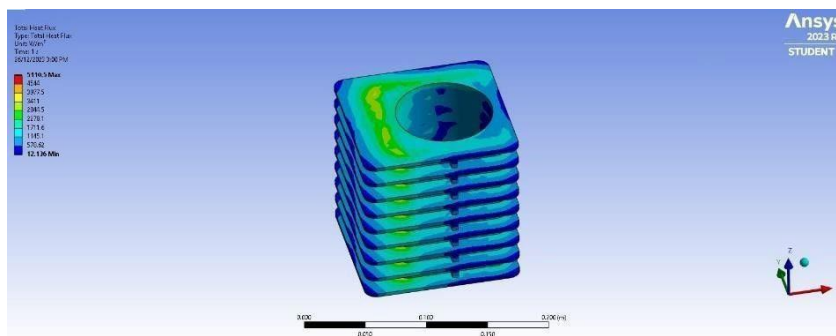
**Figure 15:** Simulation at 121.7°C

The thermal analysis experiment for RON 95, as depicted in the simulation results in Figures 13-15, reveals temperature data at three points: 99.8°C, 112.6°C, and 121.7°C. The outcomes illustrate that the temperature progression for RON 95 ranges from 99.8 to 121.7°C, representing the lowest temperature increase compared to RON 97 and RON 100.



**Figure 16:** Isoline

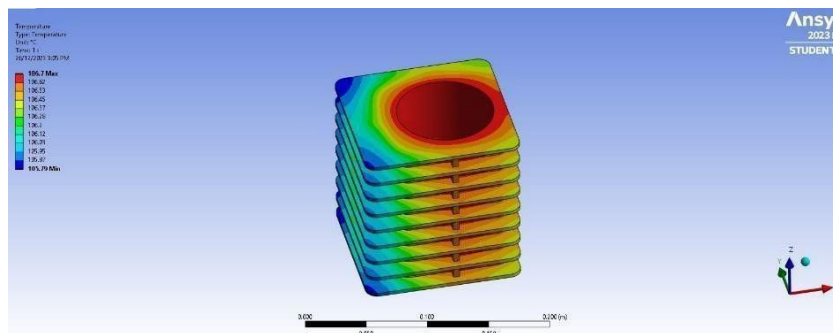
The isoline shown in Figure 16 represents RON 95 at 121.7°C provides a visual depiction of the temperature distribution across the system. Isolines, or contour lines, connect points of equal temperature, allowing for a clear visualization of the thermal profile. In the context of RON 95 at 121.7°C, the isoline map delineates areas within the system that share the same temperature, offering valuable insights into the spatial distribution of thermal energy. This visualization aids in identifying regions with uniform temperature characteristics, contributing to a comprehensive understanding of how heat is distributed throughout the analysed system at this specific temperature point.



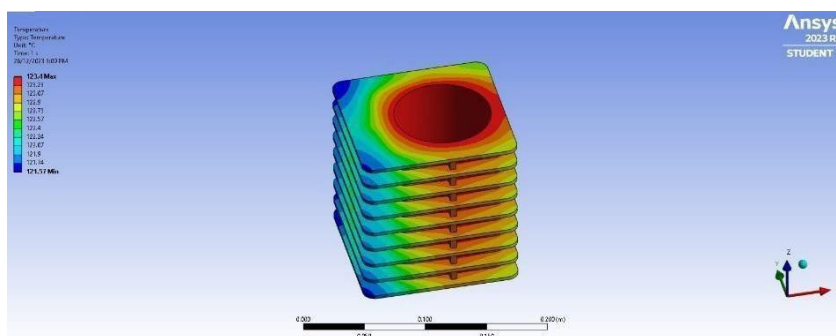
**Figure 17: Total heat flux**

The total heat flux simulation shown in Figure 17 for RON 95 fuel at 121.7°C provides a detailed representation of the heat transfer characteristics within the system. This simulation offers insights into the magnitude and direction of heat flow throughout the analysed component or structure under the specified conditions. By quantifying the total heat flux, the simulation illuminates areas of heat generation and dissipation, contributing to a comprehensive understanding of the thermal behaviour of RON 95 at this temperature. This information is crucial for assessing the efficiency of heat transfer processes, identifying potential areas of thermal stress, and optimizing the overall performance of the system under consideration.

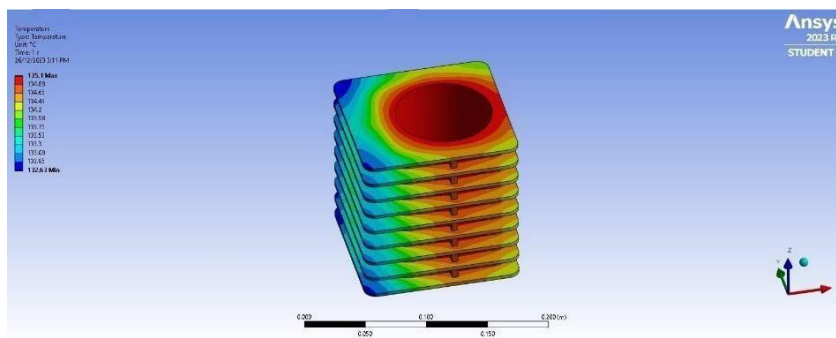
RON 97



**Figure 18: Simulation at 106.7 °C**

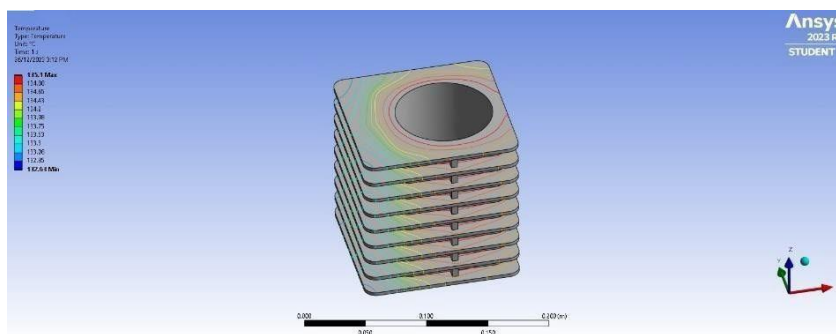


**Figure 19: Simulation at 123.4 °C**



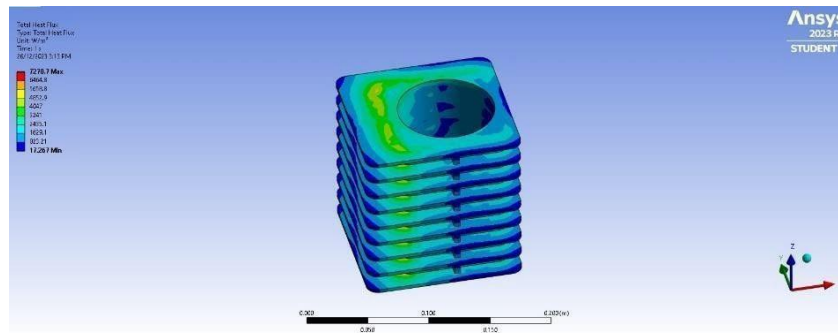
**Figure 20:** Simulation at 121.7 °C

The simulations offer an in-depth thermal analysis for RON 97, capturing temperature variations at three distinctive points: 106.7°C, 123.4°C, and 135.1°C, as illustrated in Figures 18-20. Notably, the results illuminate a discernible upward trend in temperature over the specified time intervals, concurrently reflecting changes in speed. This observed correlation between temperature increase and speed highlights the dynamic thermal behaviour of RON 97, providing valuable insights into its combustion characteristics and the consequential effects on overall engine performance. The detailed thermal analysis at multiple points enables a comprehensive examination of the fuel's response to varying operational conditions, contributing to a nuanced understanding of its thermal dynamics, and facilitating potential optimizations in engine efficiency.



**Figure 21:** Isoline

The isoline shown in Figure 21 represents RON 97 at 135.1°C offers an intricate visualization of the temperature distribution within the system. Isolines, or contour lines, connect points of equal temperature, creating a detailed map that delineates the spatial variations in thermal energy at this specific temperature. The isoline map provides a comprehensive view of regions sharing similar thermal characteristics, allowing for the identification of areas with uniform temperature profiles and those experiencing distinct thermal variations. This detailed analysis is instrumental in understanding how heat is distributed across the system at the specified temperature, providing valuable insights into potential thermal gradients, hotspots, and areas of interest. Additionally, it aids in assessing the overall thermal performance of RON 97 at 135.1°C and facilitates informed decision-making for optimizing heat management within the analysed system.



**Figure 22:** Total heat flux

The total heat flux simulation shown in Figure 22 is conducted at 135.1°C provides an extensive examination of the heat transfer characteristics within the system fuelled by RON 97. This simulation goes beyond merely quantifying temperature values by delving into the magnitudes and directions of heat flow throughout the analysed component or structure. By assessing the total heat flux, the simulation offers valuable insights into areas of intense heat generation and dissipation, contributing to a holistic understanding of the thermal dynamics of RON 97 at this specific temperature. This information is crucial for identifying potential thermal stress points, optimizing heat transfer processes, and enhancing the overall performance and efficiency of the system under consideration. The comprehensive analysis afforded by the total heat flux simulation at 135.1°C aids in making informed decisions for refining the thermal management strategies associated with RON 97 in the given operating conditions.

RON 100

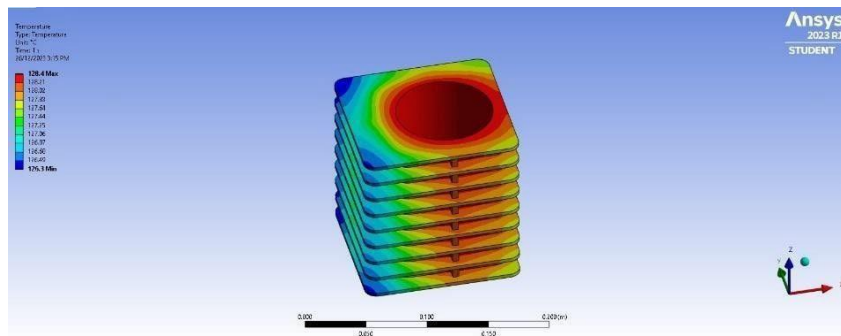


Figure 23: Simulation at 128.4 °C

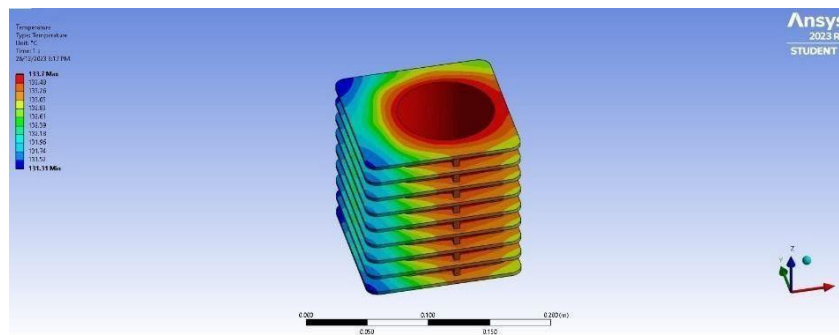


Figure 24: Simulation at 133.7 °C

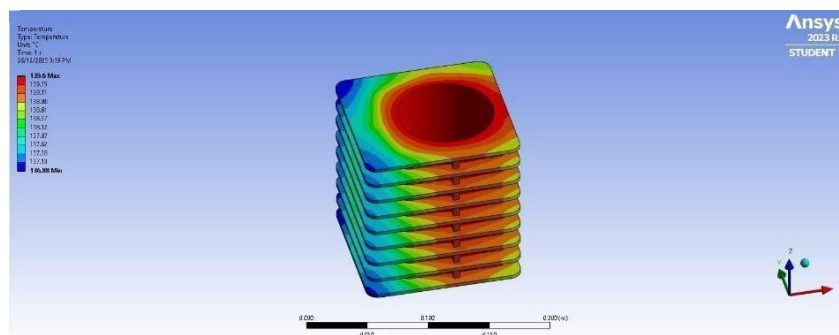


Figure 25: Simulation at 139.6 °C

The simulation reveals the experimental thermal analysis data for RON 100, indicating temperatures at 128.4°C, 133.7°C, and 139.6°C, as depicted in Figures 23-25. The findings demonstrate a consistent temperature increase from 128.4 to 139.6°C. Notably, RON 100 exhibits the highest temperatures among the fuels considered, surpassing both RON 95 and RON 97 in thermal intensity.

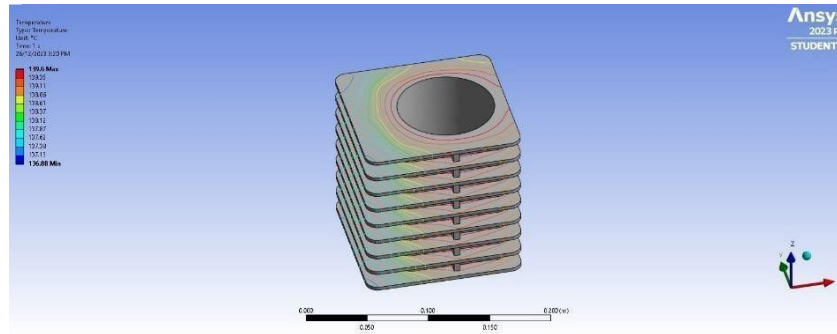


Figure 26: Isoline

The illustration shown in Figure 26 portrays the isoline for RON 100, focusing on a thermal condition where the temperature reaches 139.6°C. This isoline map serves as a comprehensive tool for visualizing the spatial distribution of temperatures within the system, emphasizing regions with similar thermal characteristics. By connecting points of equal temperature, the isoline map offers intricate insights into the thermal profile of RON 100 at this temperature. This detailed visualization aids in identifying areas with consistent thermal behaviour and variations, contributing to a nuanced understanding of how heat is distributed throughout the system. The isoline depiction at 139.6°C thus becomes instrumental in evaluating the thermal dynamics of RON 100 and pinpointing specific regions of interest or potential thermal gradients within the analysed system.

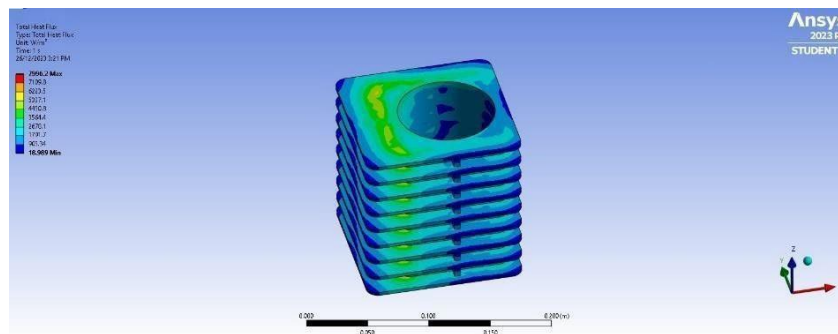


Figure 27: Total heat flux

The total heat flux simulation shown in Figure 27 is conducted for RON 100 at 139.6°C offers a detailed examination of heat transfer characteristics within the system. This analysis goes beyond temperature quantification, providing insights into magnitudes and directions of heat flow. By assessing total heat flux, the simulation identifies areas of concentrated heat generation and dissipation, crucial for optimizing system performance. This comprehensive analysis informs decisions on refining thermal management strategies specific to RON 100 in the given conditions.

#### 4.0 CONCLUSION

In summary, the experiments involving three different fuel types RON 95, RON 97 and RON 100 yielded valuable insights into their thermal behaviours. The data, meticulously collected and analysed through simulations and experiments, was aptly visualized using ANSYS and GraphPad Prism software, offering clear representations of temperature variations over time and with changing speeds. The distinct trends observed in temperature increase underscore the unique thermal characteristics of each fuel. RON 100 consistently exhibited the highest temperatures, implying potential variations in heat dissipation and combustion efficiency. The isoline and total heat flux simulations provided detailed perspectives on temperature distribution and heat transfer within the systems, enhancing our understanding of the fuels' thermal performance. These findings contribute to the broader realm of combustion studies, offering a foundation for optimizing engine efficiency and refining thermal management strategies.

#### REFERENCES (SOURCE: IEEE CITATION REFERENCE GUIDELINES)

- [1] D. Dollimore, "Thermal Analysis," *Encyclopedia of Physical Science and Technology*, pp. 591–612, 2003, doi: 10.1016/B0-12-227410-5/00770-5.
- [2] P. R. Lewis and C. Gagg, "Examination and analysis of failed components," *Forensic Polymer Engineering*, pp. 42–88, 2010, doi: 10.1533/9781845697808.42.
- [3] R. D. Bhagat, "Thermal Analysis of Combustion Chamber of Two Stroke SI Engine", Accessed: May21,2023.[Online]. Available:[https://www.academia.edu/32633298/Thermal\\_Analysis\\_of\\_Combustion\\_Chamber\\_of\\_Two\\_Stroke\\_SI\\_Engine](https://www.academia.edu/32633298/Thermal_Analysis_of_Combustion_Chamber_of_Two_Stroke_SI_Engine)
- [4] D. Nageswararao and G. Mukesh, "Thermo Structural Analysis of Two Stroke Si Engine Cylinder," *IOSR Journal of Mechanical and Civil Engineering*, vol. 16, no. 053, pp. 72–80, Dec. 2016, doi: 10.9790/1684-16053047280.
- [5] K. M. Bataineh, "Numerical thermodynamic model of alpha-type Stirling engine," *Case Studies in Thermal Engineering*, vol. 12, pp. 104–116, Sep. 2018, doi: 10.1016/j.csite.2018.03.010.
- [6] Q. Xin, "Fundamentals of dynamic and static diesel engine system designs," *Diesel Engine System Design*, pp. 299–347, 2013, doi: 10.1533/9780857090836.2.299.
- [7] Y. A. Cengel, M. A. Boles, and Y. He, "Thermodynamics An Engineering Approach. N.p.," 2009.
- [8] "Four-stroke Engine | Construction, Working & Limitations - eigenplus." Accessed: Jul. 12, 2023. [Online]. Available: <https://www.eigenplus.com/four-stroke-engine-construction-working-limitations/>
- [9] W. Dabelstein, A. Reglitzky, A. Schütze, and K. Reders, "Automotive Fuels," *Ullmann's Encyclopedia of Industrial Chemistry*, Apr. 2007, doi: 10.1002/14356007.A16\_719.PUB2.
- [10] M. Vidya Sagar and N. Suresh Assistant Professor, "Thermal Analysis of Engine Cylinder with Fins by using ANSYS Workbench", Accessed: Jun. 02, 2023. [Online].
- [11] M. Subbiah, S. Balamurugan, K. Jayakumar, and R. Karthick, "Analysis of engine cylinder block with fins by varying different materials," *Mater Today Proc*, vol. 72, pp. 2039–2043, Jan. 2023, doi: 10.1016/J.MATPR.2022.08.079.
- [12] R. D. Bhagat, "Thermal Analysis of Combustion Chamber of Two Stroke SI Engine," *International Journal of Engineering Research & Technology (IJERT)*, 2013, Accessed: May 21, 2023. [Online].
- [13] S. Seralathan, T. N. Raju, I. G. Venkat, V. Hariram, and S. Dinesh, "Thermal analysis on different exhaust valve materials of compression ignition engine," *Mater Today Proc*, vol. 33, pp. 4105–4111, 2020, doi: 10.1016/j.matpr.2020.06.550.
- [14] M. Cerdoun, C. Carcasci, and A. Ghenaiet, "An approach for the thermal analysis of internal combustion engines' exhaust valves," *Appl Therm Eng*, vol. 102, pp. 1095–1108, Jun. 2016, doi: 10.1016/J.APPLTHERMALENG.2016.03.105.
- [15] D. Dubey, D. Singh, A. Yadav, S. Pal, and H. Thakur, "Thermal Analysis of Engine Cylinder having thick tip fin with varying slot sizes and material," *Mater Today Proc*, vol. 4, no. 8, pp. 7636–7642, Jan. 2017, doi: 10.1016/J.MATPR.2017.07.097.
- [16] S. K. M. Shareef *et al.*, "Design and thermal analysis of engine cylinder fin body using various fin profiles," *Mater Today Proc*, vol. 47, pp. 5776–5780, Jan. 2021, doi: 10.1016/J.MATPR.2021.04.116.
- [17] B. J. Patil and V. Shetty, "Thermal analysis of two-wheeler engine fins," *Mater Today Proc*, vol. 46, pp. 2868–2873, Jan. 2021, doi: 10.1016/J.MATPR.2021.03.160.



- [18] S. M. Yunus, S. Hodin, F. H. Zulkifli, N. Mustafa, and S. A. Osman, "Fuel, Mixture Formation and Combustion Process The Comparative Analysis between Gasolines RON95, RON97 and RON100 on Engine Performance," *Fuel*, vol. 1, no. 2, pp. 1–7, 2019, [Online].
- [19] A. K. Rashid, M. R. A. Mansor, W. A. W. Ghopa, Z. Harun, and W. M. F. M. Wan, "An experimental study of the performance and emissions of spark ignition gasoline engine," *Int. J. Automot. Mech. Eng.*, vol. 13, no. 3, pp. 3540–3554, 2016, doi: 10.15282/ijame.13.3.2016.1.0291.
- [20] H. Geok How, Y. Heng Teoh, K. Hwa Yu, H. Guan Chuah, and K. Wen Samson Lim, "Impact of Gasoline RON on Engine Vibration, Knock and Sound Level in a Single-Cylinder SI Engine," *J. Adv. Res. Fluid Mech. Therm. Sci. J. homepage*, vol. 45, pp. 73–81, 2018, [Online]. Available: [www.akademiabaru.com/arfmts.html](http://www.akademiabaru.com/arfmts.html)